

## Carambola2 is a tiny surface mountable 2.4 GHz Wi-Fi module running OpenWRT linux software

8devices Carambola2 is a member of Carambola wireless modules family and is based on Qualcomm/Atheros AR9331 SoC.

Carambola2 is a surface mountable, single sided, Wi-Fi enabled Linux module, featuring the lowest power consumption in the industry.

Module comes in two versions:

- Commercial, operating in 0-65 °C (Carambola2)
- Industrial, operating in -40-85 °C (Carambola2-I)

8devices is providing OpenWRT linux distribution source code with necessary patches on GitHub <https://github.com/8devices>

### Quick specs

- 802.11 b/g/n, 2.4 GHz, 1x1 SISO, 150Mbps max data rate, 21 dB output power
- U.FL connector or external pin for external antenna
- 16 MB FLASH, 64 MB DDR2 RAM
- Linux friendly , OpenWRT flash image and source code are available for download on [www.8devices.com/wiki\\_carambola](http://www.8devices.com/wiki_carambola)
- CPU – AR9331, 400 MHz clock speed
- 28 by 38 mm Size – small and easy to embed
- Surface mountable
- Power supply - 3.3 V, power consumption 0.5 W
- Available interfaces - USB host/slave, serial port, 2 x Ethernet, i2S, SLIC, SPDIF, 23 x GPIO

# Table of Contents

<b>1. Pinout Information</b>	<b>3</b>
<b>2. Electrical characteristics</b>	<b>6</b>
2.1. General GPIO characteristics	6
2.2. GPIO	6
2.3. Power ratings	6
2.4. Operating conditions	6
2.5. Software	6
2.6. Power supply	7
2.7. SPI interface	7
2.8. Bootstrap	7
<b>3. Radio characteristics</b>	<b>8</b>
<b>4. Mechanical characteristics</b>	<b>9</b>
4.1. Module dimensions (with antenna/ without antenna)	9
4.2. PCB footprint	9
4.3. Soldering paste footprint	10
<b>5. Reflow profile recommendations</b>	<b>11</b>
5.1. Reflow profile parameters	11
5.2. Reflow profile	11
<b>6. Development kit</b>	<b>12</b>
6.1. Development kit interfaces	12
<b>7. Document Revision History</b>	<b>13</b>

# 1. Pinout Information

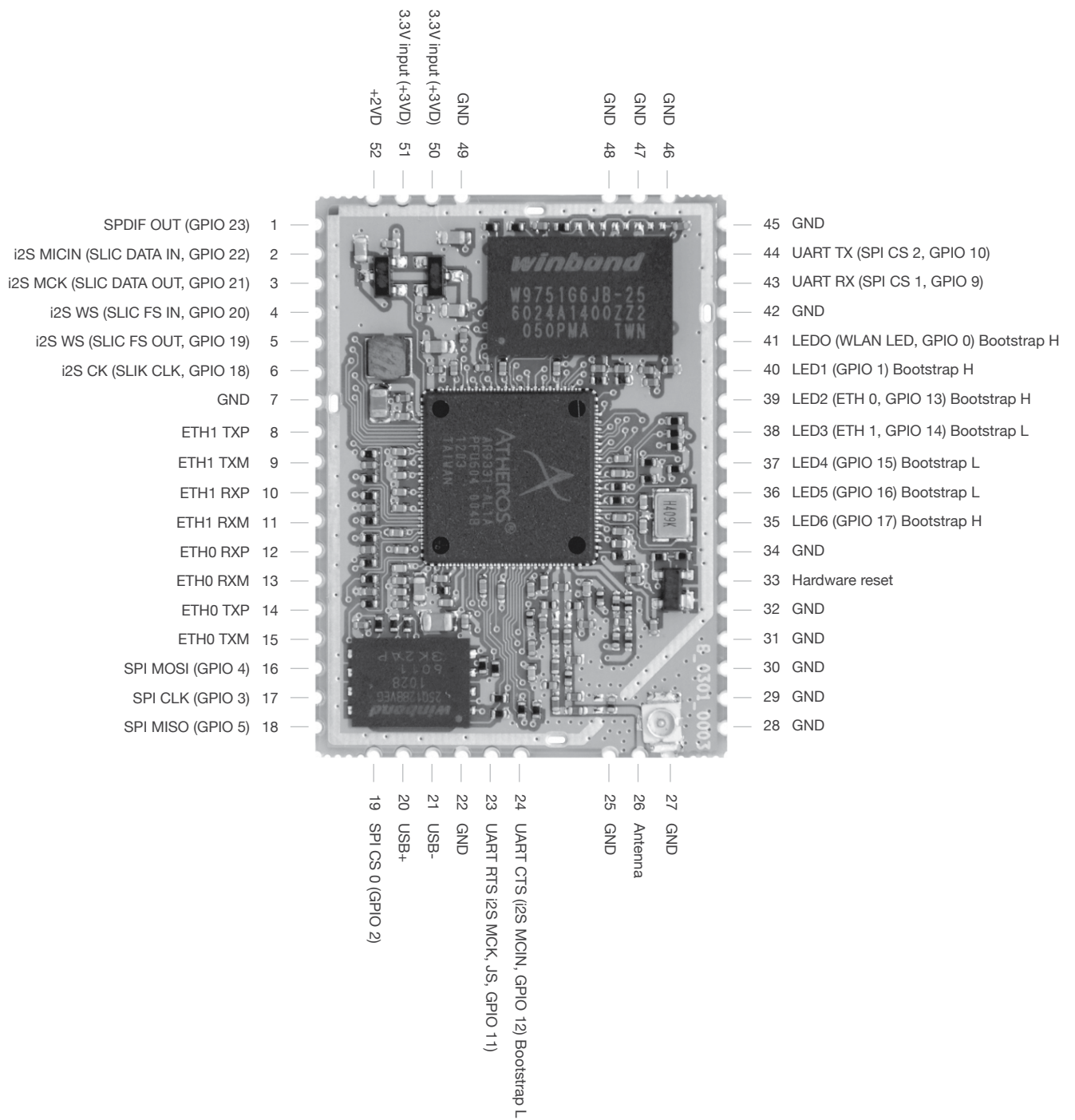

Pin	Name	I/O	Description
1	SPDIF OUT (GPIO 23)	O (I/O)	Speaker output
2	i2S MICIN (SLIC DATA IN, GPIO 22)	I (I/O)	Data input (Data transmitted from SLIC to Carambola2)
3	i2S MCK (SLIC DATA OUT, GPIO 21)	O (I/O)	Master clock (Data transmitted from Carambola2 to SLIC)
4	i2S SD (SLIC FS IN, GPIO 20)	I (I/O)	Serial data input/ output (Frame sync in)
5	i2S WS (SLIC FS OUT, GPIO 19)	O (I/O)	Word select for stereo (Frame sync out)
6	i2S CK (SLIC CLK, GPIO 18)	O (I/O)	Stereo clock (SLIC clock)
7	GND	-	Ground connection
8	ETH1 TXP	OA	LAN port 1, positive TX connection
9	ETH1 TXM	OA	LAN port 1, negative TX connection
10	ETH1 RXP	IA	LAN port 1, positive RX connection
11	ETH1 RXM	IA	LAN port 1, negative RX connection
12	ETH0 RXP	IA	LAN port 0, positive RX connection
13	ETH0 RXM	IA	LAN port 0, negative RX connection
14	ETH0 TXP	OA	LAN port 0, positive TX connection
15	ETH0 TXM	OA	LAN port 0, negative TX connection
16	SPI MOSI (GPIO 4)	O (I/O)	Data transmission from the Carambola2 to an external device. On reset, SPI_MOSI (GPIO_4) is output and can directly interface with a SPI device such as a serial flash. If a serial flash is not used, these pins may be used as GPIO pins.
17	SPI CLK (GPIO 3)	O (I/O)	SPI serial interface clock
18	SPI MISO (GPIO 5)	I/O	Data transmission from an external device to the Carambola2. On reset, SPI_MISO (GPIO_5) is input, which should be interfaced with an SPI device via a resistor divider for reliability. If a serial flash is not used, these pins may be used as GPIO pins.
19	SPI CS0 (GPIO 2)	O (I/O)	SPI chip select
20	USB+	IA/OA	Positive USB connection
21	USB-	IA/OA	Negative USB connection
22	GND	-	Ground connection
23	UART RTS (i2S MCK, JS, GPIO 11)	O	UART ready to send signal (Master clock, disables Jumpstart and WPS input function on GPIO11)
24	UART CTS (i2S MCIN, GPIO 12) Bootstrap L	I	UART clear to send signal (Data input)
25	GND	-	Ground connection
26	Antenna	I/O	External antenna connection
27	GND	-	Ground connection
28	GND	-	Ground connection
29	GND	-	Ground connection
30	GND	-	Ground connection
31	GND	-	Ground connection
32	GND	-	Ground connection
33	Hardware reset	I	Hardware reset
34	GND	-	Ground connection
35	LED6 (GPIO 17) Bootstrap H	O (I/O)	Ethernet switch LED5, Bootstrap pin high
36	LED5 (GPIO 16) Bootstrap L	O (I/O)	Ethernet switch LED4, Bootstrap pin low
37	LED4 (GPIO 15) Bootstrap L	O (I/O)	Ethernet switch LED3, Bootstrap pin low

Pin	Name	I/O	Description
38	LED3 (ETH 1, GPIO 14) Bootstrap L	O (I/O)	Ethernet switch LED2, Bootstrap pin low
39	LED2 (ETH 0, GPIO 13) Bootstrap H	O (I/O)	Ethernet switch LED1, Bootstrap pin high
40	LED1 (GPIO 1) Bootstrap H	O (I/O)	WLAN LED2, Bootstrap pin high
41	LED 0 (WLAN LED, GPIO 0) Bootstrap H	O (I/O)	WLAN LED1, Bootstrap pin high
42	GND	-	Ground connection
43	UART RX (SPI CS 1, GPIO 9)	I (O, I/O)	Serial data in (SPI chip select)
44	UART TX (SPI CS 2, GPIO 10)	O (O, I/O)	Serial data out (SPI chip select)
45	GND	-	Ground connection
46	GND	-	Ground connection
47	GND	-	Ground connection
48	GND	-	Ground connection
49	GND	-	Ground connection
50	3.3V input (+3VD)	PI	Input +3.3V
51	3.3V input (+3VD)	PI	Input +3.3V
52	+2VD	PO	+2V Ethernet power supply

**IA** – analog input signal

**I** – digital input signal

**I/O** – digital bidirectional signal

**OA** – analog output signal

**O** – digital output signal

**PO** – power output

**PI** – power input

## 2. Electrical characteristics

### 2.1. General GPIO characteristics

Parameter	Units	Min	Max
Output high voltage	V	2.44	2.8
Output low voltage	V	-0	0.1
Input high voltage	V	1.93	3.0
Input low voltage	V	-0.3	0.75

Current drive up to 24 mA.

### 2.2. GPIO

LED GPIO LED0 (GPIO0), LED2 (GPIO13) and LED3 (GPIO14) are being used by kernel module "leds\_gpio" - You can use them after removing leds\_gpio module by rmod, or removing it permanently from /etc/modules.d

**Free GPIO pins:** If you have some hoby project, it is advised to use GPIO pins 18, 19, 20, 21, 22 and 23 without any worries. These pins are not used during the booting process. Other GPIO pins should not be used if you don't know exactly what you want to achieve, because they are used during the boot process (bootstrap).

### 2.3. Power ratings

For the optimal performance and stability recommended power ratings must be used. Device might malfunction outside minimum and maximum power ratings.

Parameter	Units	Min	Nominal	Max
DC supply voltage	V	2.97	3.3	3.63
Current	A	0.09	0.110	0.450
Network transformer voltage	V	1.9	2.0	2.15

### 2.4. Operating conditions

Parameter	Units	Min	Max
Working temperature (Carambola2/Carambola2-I)	C	0/ -40	65/ 85
Storage temperature (Carambola2/Carambola2-I)	C	-40	70/ 90
Humidity	%RH	10	90
Storage humidity	%RH	5	90

### 2.5. Software

8devices is providing OpenWRT linux distribution source code with necessary patches on GitHub <https://github.com/8devices>.

## 2.6. Power supply

It is recommended to pin 50 and pin 51 for feeding the supply voltage. Use 100nF ceramic capacitors for decoupling.

## 2.7. SPI interface

SPI interface must be used carefully, it's connected to the internal FLASH memory and CS1 or CS2 must be used.

## 2.8. Bootstrap

Bootstrap HIGH or LOW means that during bootstrap process (first few seconds when the device is turned on) these pins need to be in the specified state. If pins are not in required state then device will not boot correctly.

### 3. Radio characteristics

#### 802.11N (20 MHZ)

Data rate (Mbps)	7.2	14.4	21.7	28.9	43.3	57.8	65	72.2
Sensitivity (dBm)	-94	-91	-88	-85	-82	-79	-76	-73
Output power (dBm)	21	20	20	19	18	17	16	15

#### 802.11N (40 MHZ)

Data rate (Mbps)	15	30	45	60	90	120	135	150
Sensitivity (dBm)	-89	-86	-83	-80	-78	-75	-72	-69
Output power (dBm)	20	19	19	19	18	17	16	15



## 4. Mechanical characteristics

### 4.1. Module dimensions (with antenna/ without antenna)

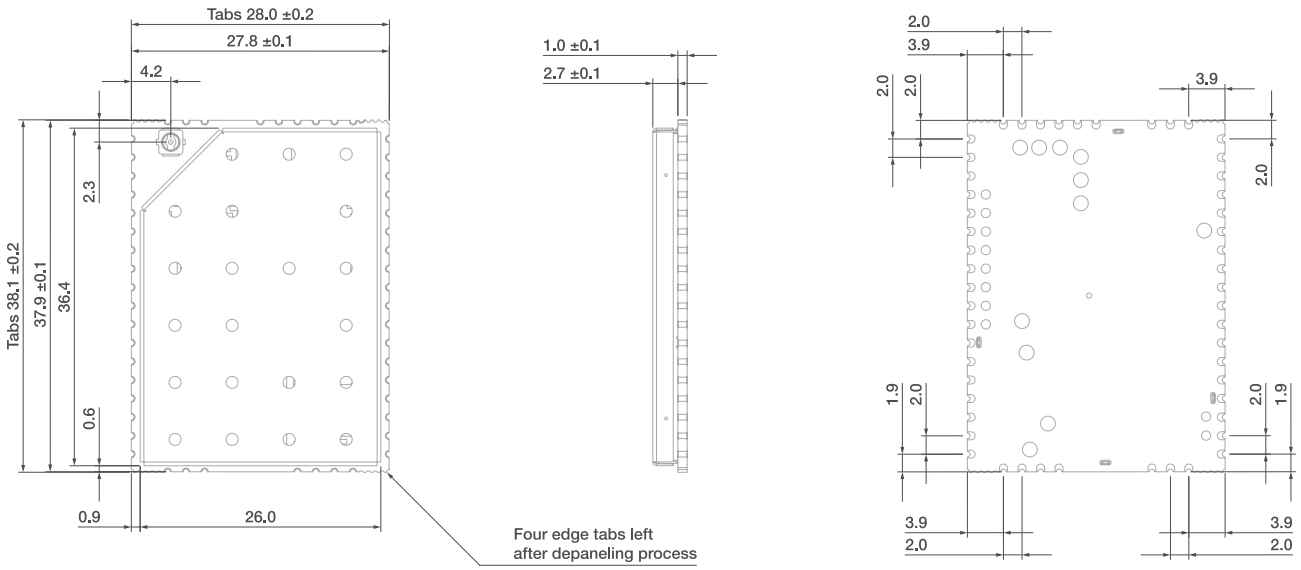

### 4.2. PCB footprint

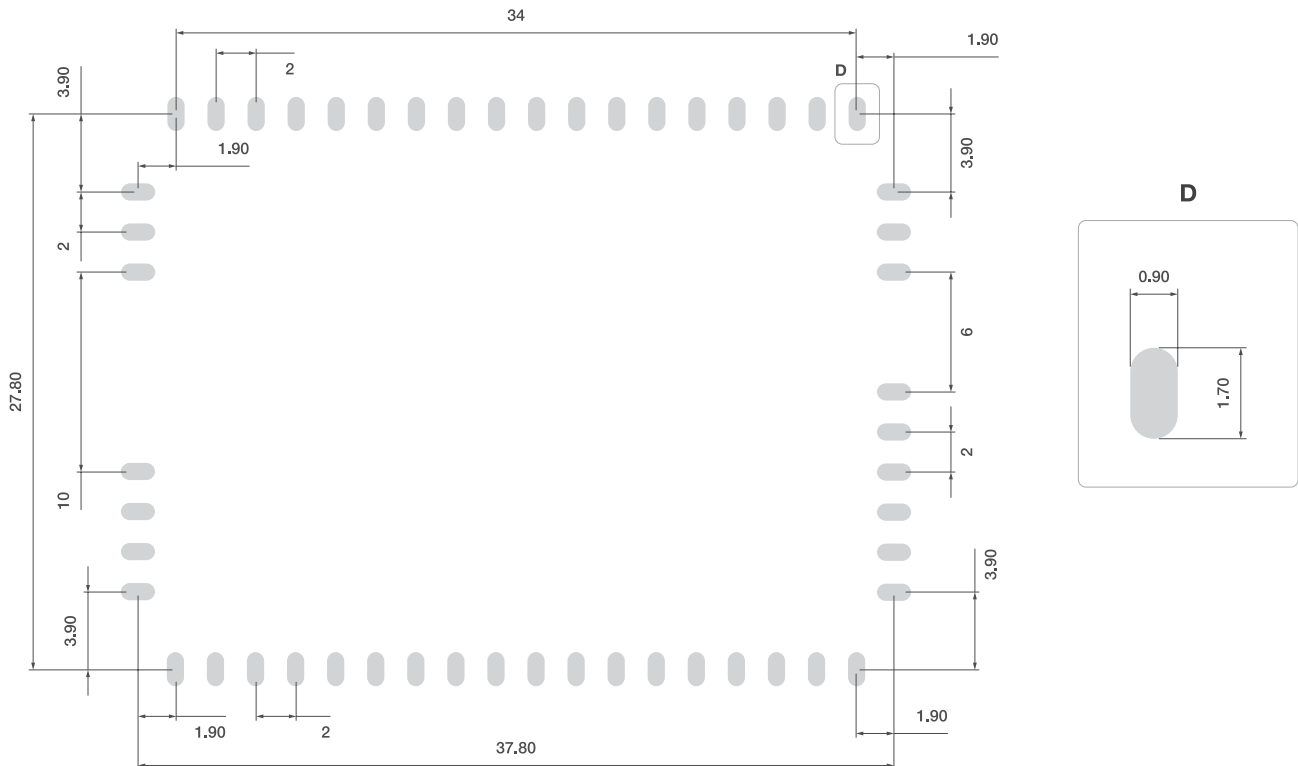

### 4.3. Soldering paste footprint

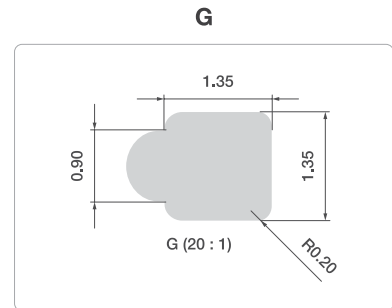
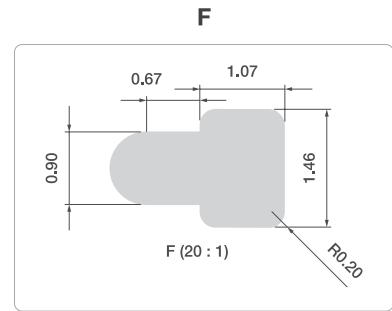
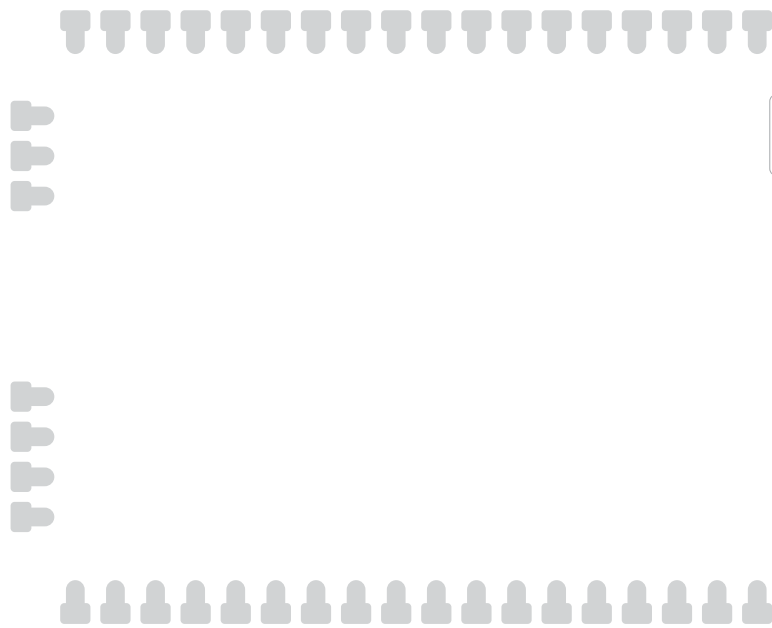

## 5. Reflow profile recommendations

### 5.1. Reflow profile parameters

Reflow profile recommendation	
Ramp up rate	3°C/second max
Maximum time maintained above 217°C	120 seconds
Peak temperature	250°C
Maximum time within 5°C of peak temperature	20 seconds
Ramp down rate	6°C/second max

### 5.2. Reflow profile

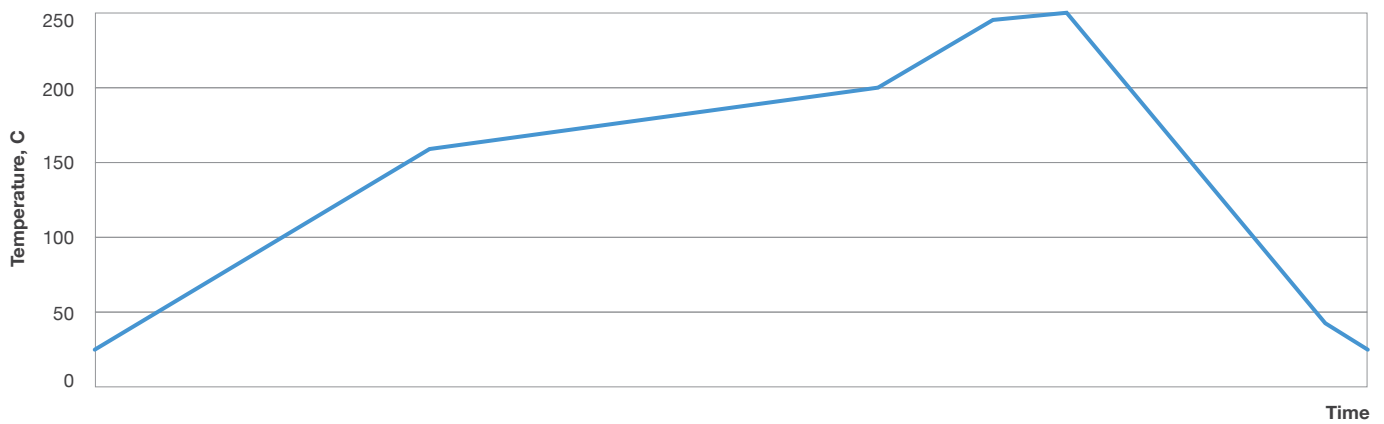

## 6. Development kit

### 6.1. Development kit interfaces

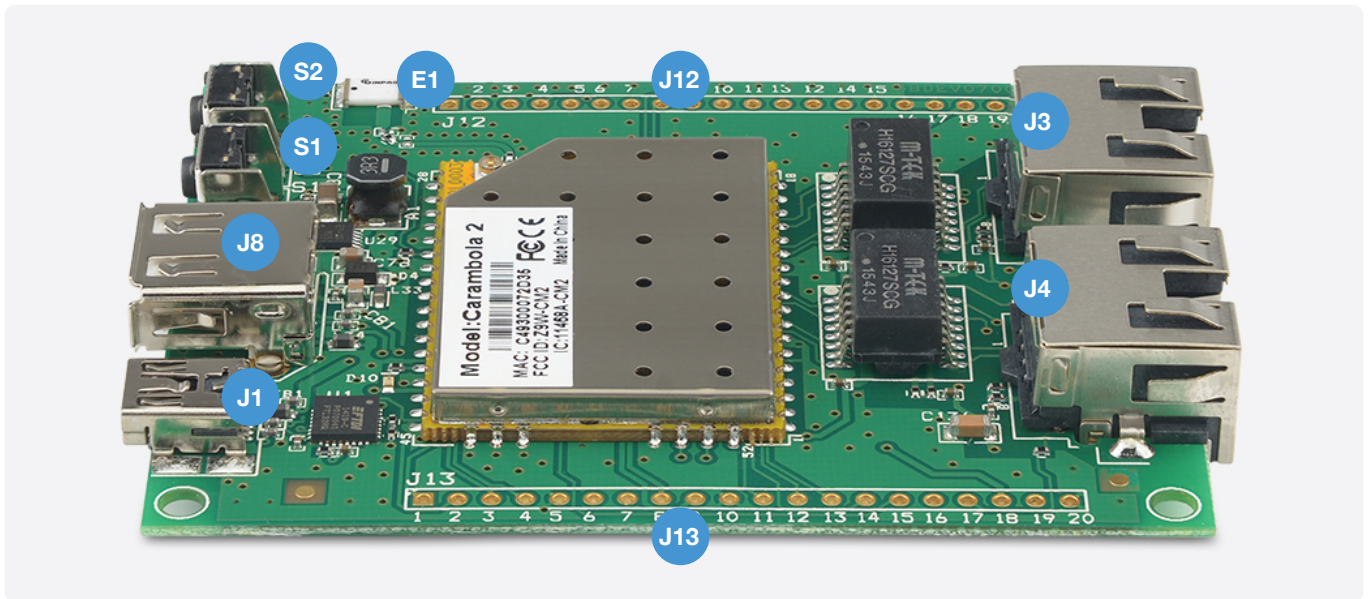

**E1** – Integrated 2.4 GHz chip antenna

**J12, J13** – 2 x 10 2.54 mm pitch prototyping area holes

**J3** – ETH0 LAN port

**J4** – ETH1 LAN port

**J8** – Type A USB socket

**J1** – Mini - A USB socket (console + power 5V)

**S1** – GPIO programmable button

**S2** – Hardware reset button

## 7. Document Revision History

Revision	Revision Date	Description
V1.0	26-09-2022	Initial release on new format